

URGENT FIELD SAFETY NOTICE – Product Recall

Device Commercial Name:

Plateau Screw - Endo-Model SL
Plateau Screw - Endo-Model Knee System
Plateau Screw - customLINK

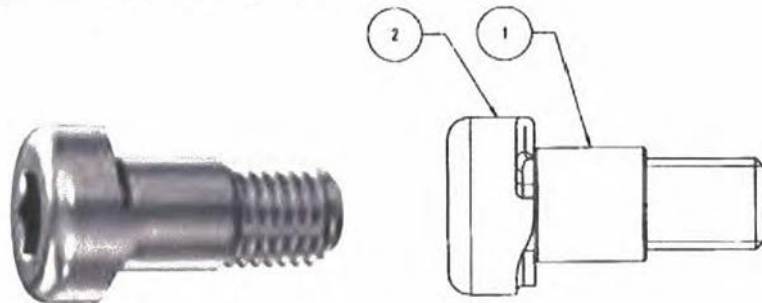

Fig. 1: Image of the plateau screw (left); technical drawing of the plateau screw (right): component 2 – screw, component 1 – bushing

For Attention of*:

- Distributor / Local branch of manufacturer
- Hospital

Contact details of local representative*:

Waldemar Link GmbH & Co. KG

Risk addressed by FSN

1. Information on Affected Device

1.1 Device Type*:

Endo-Model SL
Endo-Model Knee System
customLink

1.2 Commercial name:

Endo-Model SL:

- Connection component, incl. tibial plateau, uncemented, CoCrMo, UHMWPE, rotating hinge

Endo-Model Knee System:

- Knee joint component, cemented, CoCrMo, UHMWPE, standard, rotating hinge
- Knee joint component, cemented, CoCrMo, UHMWPE, Ti6Al4V, modular, condylar replacement, rotating hinge
- Knee joint component, cemented, CoCrMo, UHMWPE, Ti6Al4V, modular, pure hinge
- Replacement set, CoCrMo, UHMWPE, rotating hinge
- Replacement set, CoCrMo, UHMWPE, for rotating tibial plateaus

customLINK:

- Tibial component right small

1.3 Unique Device Identifier (EU UDI-DI):

Endo-Model SL:
04026575359233, 04026575359240, 04026575359257

Endo-Model Knee System:
04026575048151, 04026575383283, 04026575383238, 04026575383245,
04026575316571, 04026575431953, 04026575431960, 04026575432127,
04026575432134, 04026575316564

customLINK:
N/A

1.4 Primary clinical purpose of device*:

The non-active, surgically-invasive implantable **Endo-Model SL** and **Endo-Model Knee System** manufactured by Waldemar Link GmbH & Co. KG are intended for long-term replacement of a diseased and / or defective knee joint in the human body.

The Endo-Model SL forms a total knee replacement on its own or in combination with knee components of the Endo Model family (incl. Link OptiStem). Furthermore, the Endo-Model SL can be combined with the Megasystem-C. The Endo-Model SL Knee Joint Prosthesis is a constrained knee prosthesis, which is available in different modular configurations in two functional versions – rotating or pure hinge (alternatively in US also known as rotating and pure (non-rotating) hinge).

The Endo-Model Knee System forms a total replacement of the knee joint. The Endo-Model Standard Prosthesis is a monoblock knee surface replacement component. The intracondylar Endo-Model Rotating Hinge Knee Prosthesis is available in two versions (right and left) and four implant sizes. The external shape, dimensions and sizes of the Endo-Model Pure Hinge Knee Prosthesis correspond to those of the Endo-Model Rotating

Hinge Knee Prosthesis. As the implant beds required for the hinged and rotational versions are identical, the decision whether to use a rotational or a more stabilizing hinged knee prosthesis can be made intraoperatively.

The implants can be used with full-grown, anesthetized patients of any ethnic origin and sex. The implants are implanted with or without bone cement related to the selected implant version.

The tibial plateau is an integral component of the Endo-Model SL and Endo-Model Knee System. It is inserted into the tibial component. The fixation of the plateau is achieved using a self-locking plateau screw, which is tightened during final assembly with a hexagonal screwdriver. The plateau screw is not pre-assembled; it is supplied separately in sterile packaging and is inserted during the surgical procedure.

customLINK prostheses are custom-made and explicitly manufactured for the patient documented under an individual case number and his or her individual defect and anatomy situation and is specially adapted to the indication described by the treating physician.

The implants may only be used and operated in an aseptic medical environment by persons who have the required training, knowledge and experience in the orthopedic and surgical field. The implants are supplied in sterile condition individually packed as single-use products.

1.5 Article number(s)*:

Endo-Model SL:

16-2840/02, 16-2840/05, 16-2840/07

Endo-Model Knee System:

15-0027/11, 15-0027/12, 15-0027/15, 15-0027/16, 15-2835/12, 15-2836/11, 15-8030/12, 15-8521/09, 15-8521/11, 15-8521/15

customLINK:

11C010360 313-09079

1.6 Software version:

N/A

1.7 Affected serial or lot number range:

The listed serial and lot numbers with manufacturing dates from 2025-11-01 and 2025-12-01 are affected. A detailed list of the affected serial and lot numbers is attached to the FSN (see Annex I).

1.8 Associated devices:

N/A

2. Reason for Field Safety Corrective Action (FSCA)

2.1 Description of the product problem*:

Following a complaint, Waldemar Link was notified that an Endo-Model SL implant had been delivered with a plateau screw whose bushing had detached from the screw shaft due to a longitudinal fracture.

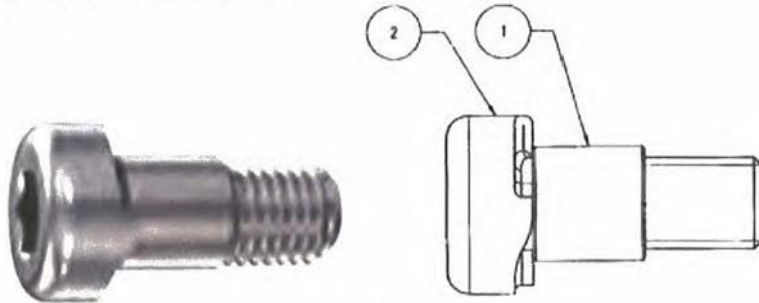

Fig. 1: Image of the plateau screw (left); technical drawing of the plateau screw (right): component 2 – screw, component 1 – bushing



Fig. 2: Bushing with longitudinal fracture

The plateau screw consists of two components, a screw and a bushing that is slid over the screw shaft and pressed into place. The bushing acts as a spacer to the tibial PE plateau.

2.2 Hazard giving rise to the FSCA*:

If the plateau screw is found in the packaging with a detached bushing, this may cause confusion as to whether the component can no longer be used due to damage or if it represents a foreign object in the packaging. Such uncertainty can lead to delays during preparation or during the procedure, potentially extending the overall surgery time. If components with a detached bushing showing a longitudinal fracture are implanted together with the screw, no significant impairment of the implant's functionality is expected. However, if the plateau retaining screw is implanted without a bushing, this is associated with an increased risk of wear, which could result in a slightly reduced standing time of the implant.

2.3 Probability of problem arising:

The probability of occurrence is classified as probable for the affected articles and serial/lot numbers.

2.4 Predicted risk to patient/users:

If a detached bushing with a longitudinal fracture remains on the screw shaft of the plateau screw and is implanted together with the screw, this has no relevant impact on the functionality of the implant. However, if the plateau screw is implanted without a bushing, this is associated with an increased risk of accelerated wear, which may result in a slightly

reduced standing time of the implant. The fundamental functionality remains preserved when used as intended.

2.5 Further information to help characterize the problem:

N/A

2.6 Background on Issue:

Waldemar Link received a complaint regarding an Endo-Model SL implant. The bushing of the plateau screw had a longitudinal fracture, causing the bushing to detach from the screw.

2.7 Other information relevant to FSCA:

N/A

3. Type of action to mitigate the risk

3.1 Action to be taken by user*:

<p><input checked="" type="checkbox"/> Identify Device</p> <p><input checked="" type="checkbox"/> Quarantine Device</p> <p><input checked="" type="checkbox"/> Return Device</p> <p><input type="checkbox"/> Destroy Device</p> <p><input type="checkbox"/> On-site device modification / inspection</p> <p><input checked="" type="checkbox"/> Follow patient management recommendations, if implanted</p> <p><input type="checkbox"/> Take note of amendment / reinforcement of Instructions For Use (IFU)</p> <p><input checked="" type="checkbox"/> Other: Custom-made replacement set can be requested.</p> <p><input type="checkbox"/> None</p> <p><u>Immediate actions:</u></p> <ul style="list-style-type: none">• If an affected product is noticed during implantation, another plateau screw from a replacement set or different LINK knee prosthesis package can be used. If this situation occurs, a complaint form must be completed and sent to Complaint@link-ortho.com. <p><u>Long-term actions:</u></p> <ul style="list-style-type: none">• The replacement of the affected products will begin as soon as replacement products are available. Replacement will not incur any costs to you. Should you have any questions on acquiring replacements for forthcoming surgeries, please contact your local sales representative or customer service for Link products.• Please return the reply form to us in any event until the 23.01.2026 as documentation of the recall. This applies even if you have none of the listed products in stock or if these products do not exhibit the defect in question.

3.2 By when should the action be completed?:

23.01.2026 – Return of the customer reply form 27.02.2026 – Return of products should be completed

3.3 Particular considerations for implantable device: Is follow-up of patients or review of patients' previous results recommended?

<input type="checkbox"/> Yes, the following:	<input checked="" type="checkbox"/> No, because: Regular patient follow-up is sufficient.
--	---

3.4 Is customer Reply Required?*

<input checked="" type="checkbox"/> Yes, until: 23.01.2026	<input type="checkbox"/> No
--	-----------------------------

3.5 Action being taken by the manufacturer:

<input checked="" type="checkbox"/> Product Removal <input type="checkbox"/> On-site device modification / inspection <input type="checkbox"/> Software upgrade <input type="checkbox"/> IFU or labelling change <input type="checkbox"/> Other <input type="checkbox"/> None
--

3.6 By when should the action be completed?

23.01.2026 – Return of the customer reply form 27.02.2026 – Return of products should be completed 13.03.2026 – Review of customer reply forms and product returns 31.03.2026 – Planned completion of FSCA

3.7 Is the FSN required to be communicated to the patient /lay user?

<input checked="" type="checkbox"/> Yes, if the bushing is not implanted together with the plateau screw. <input type="checkbox"/> No <input type="checkbox"/> N/A
--

3.8 If yes, has manufacturer provided additional information suitable for the patient/lay user in a patient/lay or non-professional user information letter/sheet?

<input type="checkbox"/> appended to this FSN <input checked="" type="checkbox"/> not appended to this FSN

4. General Information

4.1 FSN Type*:

New Update

4.2 For updated FSN

Reference number of previous FSN: N/A
Date of previous FSN: N/A

4.3 For updated FSN, key new information as follows:

N/A

4.4 Further advice or information already expected in follow-up FSN?*

Yes No Not planned yet

4.5 If follow-up FSN expected, what is the further advice expected to relate to?:

N/A

4.6 Anticipated timescale for follow-up FSN:

N/A

4.7 Manufacturer information:

Waldemar Link GmbH & Co. KG

4.8 The Competent (Regulatory) Authority of your country (EU) has been informed about this communication to customers*:

Yes No

4.9 List of attachments/appendices:

Annex I: Affected serial or lot number range

4.10 Name/Signature:

Digital
unterscrieben von
Datum: 2026.01.12
14:17:43 +01'00'

Annex I: Affected serial or lot number range

Endo-Model SL					
Article	Serial number	Article	Serial number	Article	Serial number
16-2840/02	250925/0640	16-2840/02	250925/0651	16-2840/05	250513/2091
	250925/0641		251110/3297		251013/3246
	250925/0642		251110/3289		251105/0019
	250925/0646		250925/0639		251013/3249
	250925/0650		250925/0648		251105/0011
	250925/0652		250925/0688		251105/0012
	250925/0653		250925/0696		250513/2103
	250925/0656		250513/2083		250513/2105
	250925/0658		250513/2085		251013/3254
	250925/0669		250513/2086		250925/0480
	250925/0670	250513/2089	250925/0481		
	250925/0680	250513/2090	250925/0482		
	250925/0681	250513/2092	250925/0483		
	250925/0682	250513/2093	250925/0484		
	250925/0687	250513/2097	250925/0486		
	250925/0689	250513/2100	250925/0489		
	250925/0690	250513/2102	250925/0491		
	250925/0691	250513/2104	250925/0492		
	250925/0693	250513/2107	250925/0494		
	250925/0694	250513/2108	250925/0503		
	251110/3293	251013/3245	250925/0504		
	250925/0660	251013/3247	250925/0345		
	250925/0661	251013/3250	250925/0346		
	250925/0684	251013/3251	250925/0349		
	250925/0685	251013/3252	16-2840/07	250925/0350	
	250925/0657	251013/3253	250925/0351		
	250925/0663	251105/0013	250925/0352		
	250925/0659	251105/0016	250925/0356		
	250925/0678	251105/0018	250925/0369		
	251110/3288	251105/0020	250925/0501		
	251110/3292	251105/0032	250925/0365		
	251110/3303	251105/0034	250925/0368		
	251110/3313	251105/0036	250925/0490		
	250925/0683	251105/0037	250925/0488		
	250925/0674	251105/0038	250925/0479		
	250925/0644	251105/0039	250925/0495		
	250925/0665	250513/2106	250925/0500		
	250925/0668	250513/2099	250925/0496		
	250925/0671	251105/0014	250925/0499		
	250925/0673	251105/0040	250925/0367		
	250925/0676	251105/0002			
	250925/0664	250513/2087			

Endo-Model Knee System			
Article	Serial number	Article	Lot number
15-2835/12	241210/1809		
	250623/3643	15-0027/11	2549126
	250623/3644		2549127
	250623/3645	15-0027/12	2549036
15-2836/11	250623/3646	15-0027/15	2549190
	250623/3648		2550412
	250812/2812	15-0027/16	2550413
	250812/2811		2549228
	250721/0194		
15-8030/12	250721/0212		
	250721/0211		
	250721/0209		
	250728/0038		
	250728/0039		
15-8521/09	250728/0040		
	250728/0041		
	250728/0042		
	250728/0043		
	250728/0044		
	250728/0045		
	250728/2220		
	250728/2222		
	250728/2223		
15-8521/11	250728/2224		
	250728/2225		
	250728/2226		
	250728/2227		
	250805/0020		
15-8521/15	250805/0021		
	250805/0023		
	250805/0024		

customLINK	
Article	Serial number
11C010360 313-09079	250610/3181

Transmission of this Field Safety Notice

This notice needs to be passed on all those who need to be aware within your organisation or to any organisation where the potentially affected devices have been transferred. (As appropriate)

Please transfer this notice to other organisations on which this action has an impact. (As appropriate)

Please maintain awareness on this notice and resulting action for an appropriate period to ensure effectiveness of the corrective action.

Please report all device-related incidents to the manufacturer, distributor or local representative, and the national Competent Authority if appropriate, as this provides important feedback.

Note: Fields indicated by * are considered necessary for all FSNs. Others are optional.